

LUCAS

Quality

EQUIPMENT

WORKSHOP INSTRUCTIONS

MAGNETOS

MODELS

SRI, SR2 and SR4



JOSEPH LUCAS LTD · BIRMINGHAM 19 · ENGLAND

LUCAS WORKSHOP INSTRUCTIONS

MAGNETOS

MODELS SR1, SR2 and SR4

1. GENERAL

The SR range of magnetos is suitable for use with single-cylinder, twin-cylinder and four-cylinder petrol engines. They may be base or flange mounted, for engine-speed or half-engine-speed drives, with screened or un-screened cables and covers.

Great care has been taken to prevent the ingress of dirt and moisture. The body is formed of a single pressure die-casting enclosed at the contact breaker end by a cable cover specially designed to prevent retention of moisture at the terminal connections. Unscreened magnetos have a cork gasket positioned between the magneto body and a moulded cable cover. Screened magnetos have an aluminium gasket positioned between the magneto body and a metal cable cover.

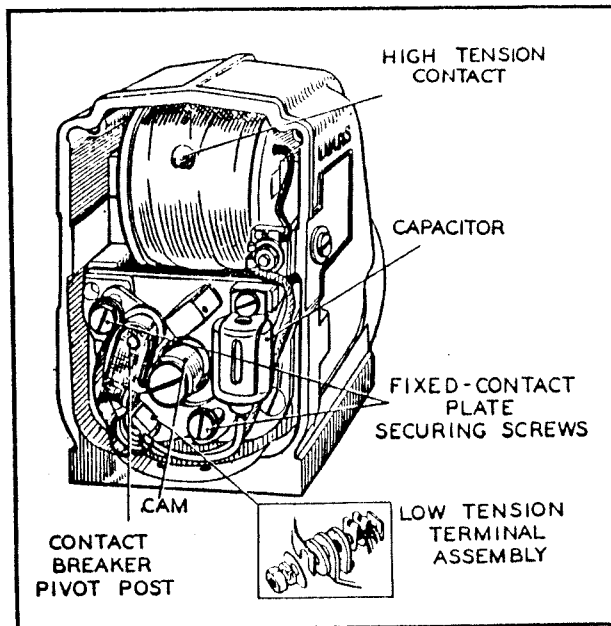

Fig. 1.
Model SR1 with cable cover removed

HOW THE MAGNETO WORKS

The magneto shaft, permanent magnet and laminated pole shoes form a single diecast assembly known as the rotor. This, supported on ball bearings, rotates

between a pair of laminated pole pieces in the stator. These stator pole pieces are bridged by the laminated core of a coil having a primary winding of relatively few turns of thick wire and a secondary winding of many turns of fine wire. A contact breaker is arranged to interrupt the primary circuit at the instant a spark is required.

The rotor is driven by the engine and this rotation produces an alternating magnetic field in the laminated iron core of the coil. This field induces low tension alternating voltages in the primary and secondary windings of the coil. The magnetic field due to current flowing in the primary winding opposes any change in direction of the magnetic field in the laminated iron core. In this way, field reversal due to the rotating magnet is delayed until the contact breaker opens. At this instant, the restraining influence of the primary winding is removed and the consequent rapid reversal of the magnetic field, linked with the coil, causes a high voltage to be induced in the secondary winding.

With single-cylinder magnetos, this high voltage is conducted direct to the plug through the high tension cable, but in multi-cylinder magnetos it is taken to a rotating electrode and distributed to each plug in turn.

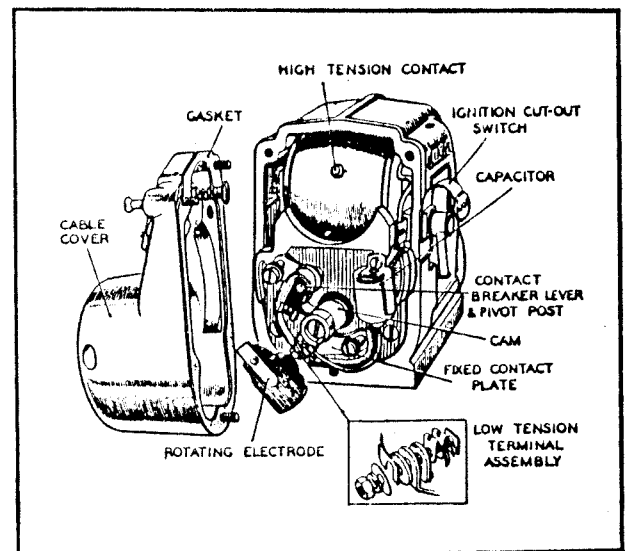

Fig. 2.
Model SR2 (half engine speed) with cable cover removed



LUCAS WORKSHOP INSTRUCTIONS

IMPULSE STARTER (WHEN FITTED)

An impulse starter consists of two members flexibly coupled by a clock type spring. One member is secured to the magneto shaft whilst the other carries the driving dogs or sprocket. When cranking the engine, that member secured to the magneto shaft is at first prevented from turning by a trip lever. The coupling spring is therefore wound up until a projection on the driving member trips the lever. The magneto rotor is then rapidly accelerated through the sparking position. This sequence is repeated until the engine starts and the trip levers are held out of engagement by centrifugal force.

An impulse starter improves the low speed performance and hence facilitates manual starting of an engine, by increasing the intensity and delaying the instant of sparking.

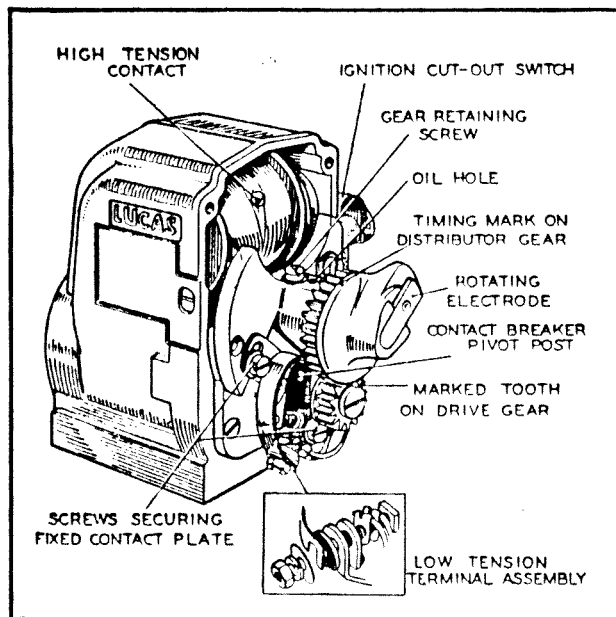

Fig. 3.

Model SR4 or SR2 (engine speed) with cable cover removed

AUTOMATIC TIMING CONTROL (WHEN FITTED)

An automatic timing control mechanism is a centrifugally operated mechanism, enabling an angular movement of the magneto shaft to occur relative to the drive. The mechanism consists of two members flexibly coupled by pivoted spring-loaded governor weights and toggles. During starting and at low engine speeds, the weights are held in by the action of the springs. As the engine speed increases, the weights swing out and advance the rotor relative to the drive.

An automatic timing control improves the performance

of an engine by advancing the spark at higher speeds, so ensuring maximum power output.

CUT-OUT SWITCH (WHEN FITTED)

A cut-out switch is connected between the 'live' side of the primary winding of the coil and earth. Operation of this switch cuts out the ignition and stops the engine.

A terminal is also incorporated from which a connection may be taken to an earthing switch, on the control panel or some other convenient position.

If the cut-out switch is more easily accessible on the opposite side of the magneto, it can be re-positioned using a special kit which is available for this purpose.

2. ROUTINE MAINTENANCE

(a) AFTER THE FIRST 20 RUNNING HOURS

During the first 20 hours' running of a new magneto or replacement contact breaker set, most of the bedding-down of the contact breaker heel occurs. The contact breaker should therefore be checked and, if necessary, reset as described in the instructions for servicing every 300 running hours.

(b) EVERY 150 RUNNING HOURS

Apply a spot of engine oil to the visible end of the contact breaker pivot post.

With magnetos of the type shown in Fig. 3, inject a few drops of thin machine oil into the distributor gear oil hole.

NO OIL MUST BE ALLOWED ON OR NEAR THE CONTACTS.

In some earlier magnetos the rotating electrode carried the words 'Remove to Oil'. This instruction must be ignored on model SR magnetos.

(c) EVERY 300 RUNNING HOURS OR MONTHLY

Clean the outside of the magneto and the high tension cables using a clean fluffless cloth.

Ensure that all ventilating holes or notches in the base and cable cover are clear.

Remove the cable cover and examine the contact breaker.

Ensure that the contacts are smooth and clean and that the gap is correctly set.

Cleaning the Contact Breaker

Before attempting to clean the contact breaker, the contact breaker lever should be removed.



LUCAS WORKSHOP INSTRUCTIONS

To remove the contact breaker lever, slacken the nut securing the slotted end of the contact breaker spring and withdraw the spring and lever. Because the end of the spring is slotted, complete removal of the nut is not necessary. If, however, this nut is removed, it is most important that the components are reassembled in the order shown in Figs. 1, 2 and 3.

With unscreened magnetos of the type shown in Fig. 2, it is necessary to withdraw the rotating electrode before the contact breaker lever can be lifted off its pivot post. When refitting the rotating electrode, see that the projection in the moulding engages with the slot in the carrier, and then push the moulding fully home.

With screened and unscreened magnetos of the type shown in Fig. 3, slacken the distributor gear retaining screw and withdraw the moulded distributor gear. Slacken the two screws which secure the fixed contact plate and pivot the plate and terminal assembly to the fullest extent of the adjusting slots. The contact breaker lever can now be lifted off its pivot post without disturbing the small diecast driving gear. When refitting the moulded distributor gear, see that the marked teeth of the moulded and diecast gears engage.

Rough or pitted contacts should be polished with fine carborundum stone, silicon carbide or emery cloth.

After polishing, clean the contacts with petrol or methylated spirits (denatured alcohol).

Checking the contact breaker setting

Crank the engine slowly until the contacts are fully open and insert a 0.010" to 0.012" or a 0.25 mm. to 0.3 mm. feeler gauge in the gap.

If the gap width is correct, the gauge will be a sliding fit between the contacts.

To adjust the gap, slacken the two screws securing the fixed contact plate and move the plate until the gap is set to the thickness of the gauge.

Tighten the two screws.

Cleaning the Cable Cover

Wipe the inside of the moulding using a clean fluffless cloth.

With multi-cylinder machines, check that the carbon brush and in earlier magnetos the brass contact stud, move freely in their holders.

Before refitting, check that a sealing gasket, in good condition, is positioned between the cable cover and magneto body.

(d) EVERY 1,000 RUNNING HOURS OR EVERY THREE MONTHS

Remove the contact breaker lever from its pivot post and smear the post with Mobilgrease No. 2.

(e) EVERY TWO YEARS

About every two years, or when the engine is overhauled the magneto should be dismantled and the bearings re-packed with grease, as described in para. 4.

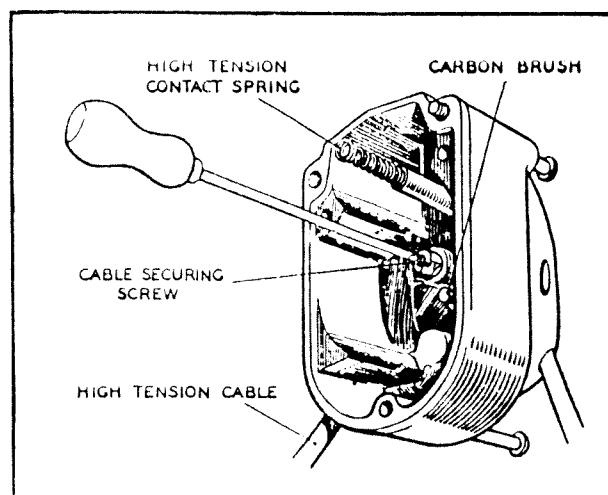

Fig. 4.
High tension cable connection

(f) REPLACEMENT OF HIGH TENSION CABLES

Unscreened Cables

Occasionally inspect the cables between the cable cover and the sparking plugs.

If the cables pass through conduits, carefully examine the cables at the conduit entries. Lightly pull out the cables to inspect that portion which is just inside the conduit.

Replace any cables which have cracked or damaged insulation.

Replacement cable must be 7 mm. (p.v.c.-covered or neoprene-covered) rubber insulated ignition cable.

When connecting a new cable to the magneto do not bare the cable but cut it off flush to the required length.

Remove the cable cover, unscrew the pointed screws from the inside of the cover and pull out the old cable, see Fig. 4.

Push the new cable fully home and secure by tightening the screw. This will pierce the insulation, make contact with the cable core, and lock the cable in place.

After fitting a new cable make a continuity check between the cover electrode and plug end. A flashlamp battery and bulb can be used to make this test.



LUCAS WORKSHOP INSTRUCTIONS

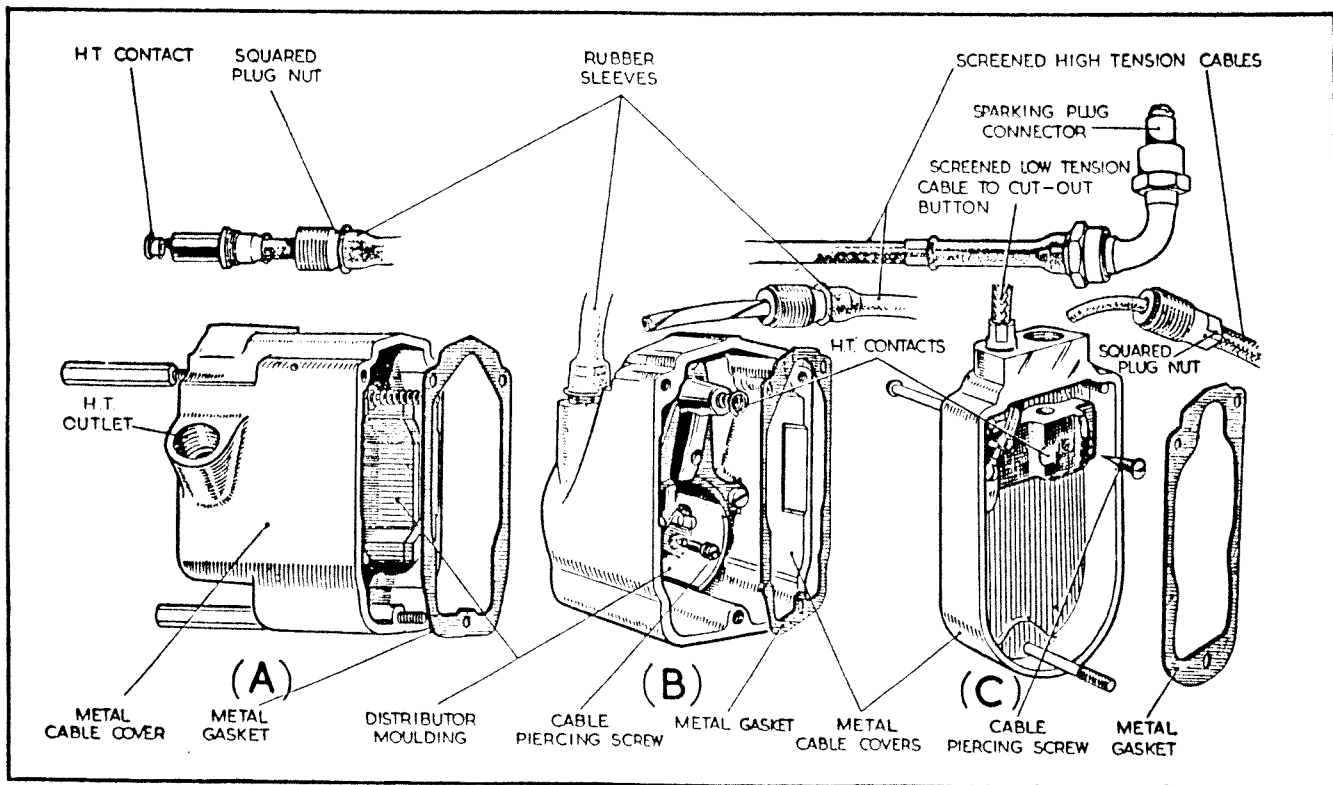

Fig. 5.
Typical screened cable covers

Screened cables of the type shown in Fig. 5 (A)

A defective screened cable must be renewed complete with braiding.

Pull back the waterproof sleeve, unscrew the squared plug nut and withdraw the defective cable.

Insert the H.T. contact on the replacement cable in the H.T. outlet hole.

Screw in the squared plug and position the rubber sleeve over it.

Screened cables of the type shown in Fig. 5 (B) and (C)

A defective screened cable must be renewed complete with braiding.

Remove the cable cover and then disconnect the internal cable connection.

Pull back the waterproof sleeve, unscrew the squared plug nut and withdraw the defective cable.

Insert the replacement cable into the cable cover and make the internal connection.

Tighten the squared plug nut and position the rubber sleeve over it.

Check that the metal gasket is correctly positioned between the cable cover and body and replace the cable cover.

3.

TEST DATA

(a) Contact breaker gap:

0.010"—0.012" (0.25 mm.—0.3 mm.)

(b) Contact breaker spring tension: 18—24 oz.

(c) Capacitor: 0.18—0.23 microfarad

(d) High speed test:

Regular sparking should occur at all speeds between 1,000 r.p.m. and 3,000 r.p.m. on a rotary gap set at 8 kv. with a load of 2.5 micromhos.

(e) Slow speed test:

The magneto should spark, with not more than 5% missing, on a 5.5 mm. 3-point spark gap at 140 r.p.m. for single-cylinder magnetos, 150 r.p.m. for half-engine-speed twin-cylinder magnetos and 180 r.p.m. for twin-cylinder engine speed and four-cylinder magnetos. If an impulse starter is fitted it must be removed before this test is carried out.

(f) Re-magnetisation:

If a correctly timed magneto gives very weak sparking in tests (d) and (e), the magneto should be re-magnetised as described in SECTION D-6.

(g) Impulse starter:

This should operate regularly at speeds up to 100 r.p.m. and have cut out completely at a maximum speed of



LUCAS WORKSHOP INSTRUCTIONS

220 r.p.m. The retard due to the impulse starter varies with the engine to which the magneto is fitted.

(h) Automatic timing control:

Test data for automatic timing control mechanisms is given under the appropriate Magneto Service No. in Lucas Publication SB 222.

4. SERVICING

(a) TESTING IN POSITION TO LOCATE CAUSE OF UNEVEN FIRING

Remove the cable from each sparking plug terminal in turn, position the end of the cable about $\frac{3}{16}$ " (5 mm.) from the cylinder head and crank the engine.

If sparking is strong and regular, the fault lies with the sparking plug, which should be removed, cleaned and adjusted or a replacement plug fitted.

If however there is no spark, examine and renew the high tension cables as described in para. 2.

Under certain conditions, a film of hydrated tungsten oxide can appear on the contacts. Examine, and if necessary clean, the contacts of a magneto which has been in storage or only occasionally in use.

If a remote cut-out switch is fitted, disconnect the switch cable at the low tension terminal on the magneto body, and crank the engine. If the magneto now functions correctly, inspect the cable and switch for a short circuit to earth.

Capacitor

The possible causes of capacitor trouble, and the symptoms by which each may be recognised, are:

- (i) Open circuit, indicated by excessive burning at the contacts.

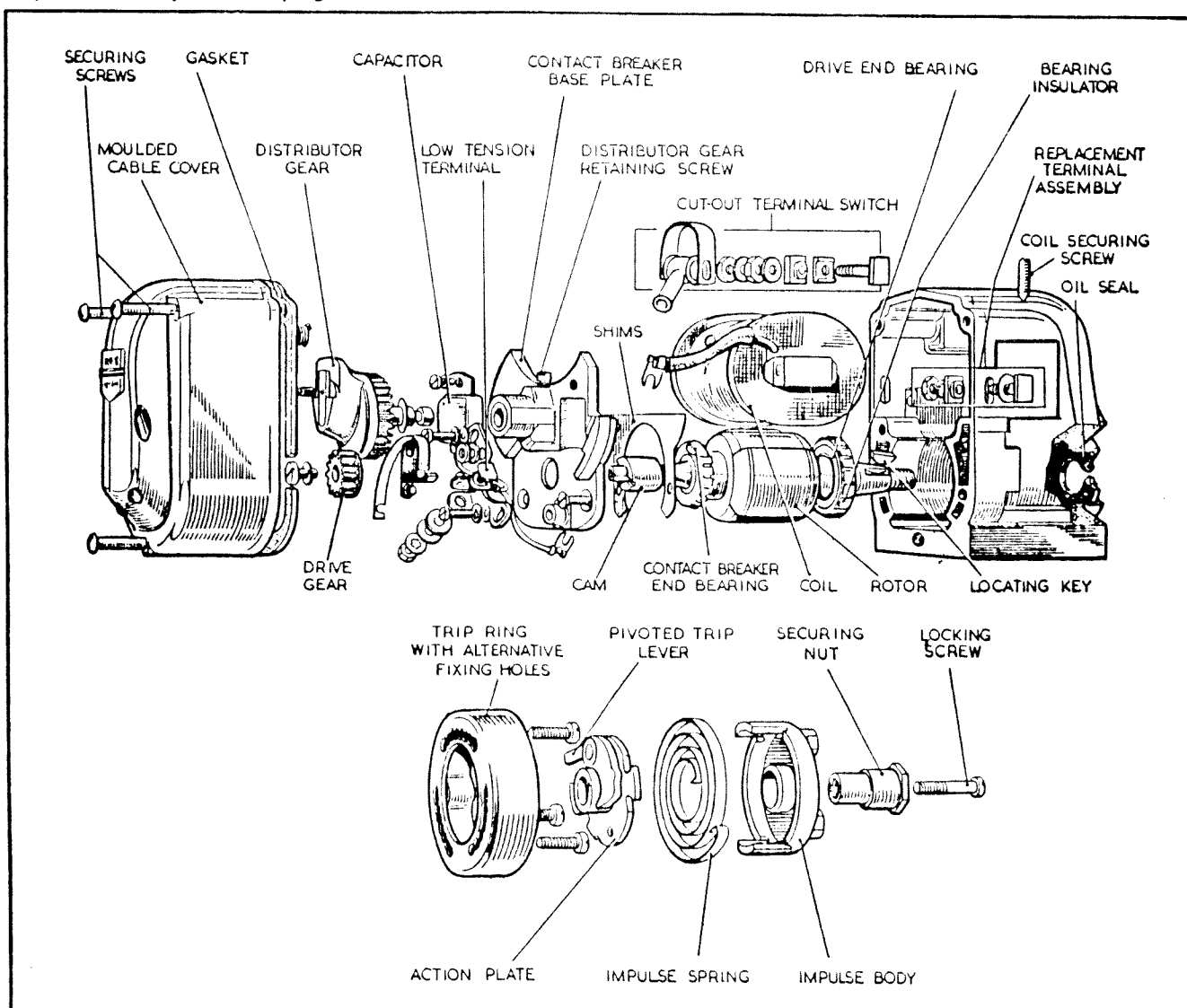

Fig. 6.
Model SR4 dismantled



LUCAS WORKSHOP INSTRUCTIONS

(ii) Short circuit, indicated by complete failure of ignition and no sparking at the contacts when the magneto is turned by hand.

(iii) Abnormally low insulation resistance when magneto has warmed up, indicated by poor low speed performance.

It should be noted that loose or dirty connections to the capacitor will produce the same symptoms as (i), and that in the case of (iii) the insulation resistance must fall to less than 1 megohm before ignition performance is appreciably affected.

The capacitor is secured to the contact breaker base by means of a clip retaining screw and spring washer. If the cause of faulty operation cannot be traced from the foregoing checks, the magneto should be removed from the engine for dismantling.

(b) DISMANTLING

When dismantling it is essential to work at a bench which is clean and free from iron swarf.

(i) Remove the magneto from the engine.

Magnetos fitted with automatic timing control

(i) Unscrew the securing nut and withdraw the automatic timing control from the magneto shaft.

Magnetos fitted with impulse starters

(i) Withdraw the securing screw, which has a left hand thread, from the magneto shaft and unscrew the securing nut

(ii) Withdraw the impulse starter from the magneto shaft. If any difficulty is experienced, the impulse starter body should be lightly hammered around its periphery. This will gradually loosen the impulse starter on the tapered shaft.

(iii) Remove the locating key from the shaft.

(iv) Pull the body from the action plate and remove the impulse spring.

Magnetos having a distributor gear

(i) Loosen the three cable cover securing screws and remove the cover.

(ii) Mark the distributor gear and drive gear with spots of paint to ensure the correct timing of the distributor on reassembly.

(iii) Slacken the distributor gear retaining screw and withdraw the gear.

(iv) Remove the screw securing the drive gear and withdraw the gear from the magneto shaft.

All Magnetos

(i) Loosen the cable cover securing screws and remove the cover.

(ii) Unscrew the low tension terminal assembly securing nut, lift off the contact breaker spring and remove

the three washers. Withdraw the square-headed bolt, insulation piece and connections.

(iii) Withdraw the three screws securing the contact breaker base and withdraw the contact breaker base plate.

(iv) Remove any shims which may be fitted between the base plate and magneto body.

(v) Disconnect the lead from the coil at the cut-out terminal post (or replacement terminal post if the cut-out has been re-positioned).

(vi) Scoop out the sealing compound from the two holes in the top of the magneto body and withdraw the coil securing screws.

(vii) Withdraw the coil from the magneto body.

(viii) Pull the rotor out of the magneto body.

(ix) Unscrew the securing nuts and remove the cut-out terminal post, washers and insulation pieces.

(x) If the cut-out switch has been re-positioned, unscrew the securing nut and remove the replacement terminal post, washers, connections and insulation pieces.

(c) REFITTING BEARINGS

The two shaft bearings must be in good condition. If any part of the bearing assembly shows signs of wear, a new assembly, comprising inner and outer races, balls and cages, and a new bearing insulator must be fitted.

Before the inner race of the contact breaker end bearing can be withdrawn, the cam must be removed. Note the position of the slots in the end of the cam with relation to the keyway at the driving end of the shaft and maintain this relationship when refitting the cam.

(i) Pull the inner races off the magneto shaft and the outer races from their housings using bearing extractors.

(ii) Remove the bearing insulators from the bearing housings.

(iii) Pack the new bearings with clean high-melting-point grease.

(iv) Fit the inner races on the magneto shaft using a hand-press and suitable sleeve. Ensure that the bearing spacer ring is located between the shoulder on the magneto shaft and the inner race of the drive end bearing.

(v) Position the new balls and cages on the races.

(vi) Fit new bearing insulators into the bearing housings.

(vii) Press the outer races into the bearing housings using a mandrel.



LUCAS WORKSHOP INSTRUCTIONS

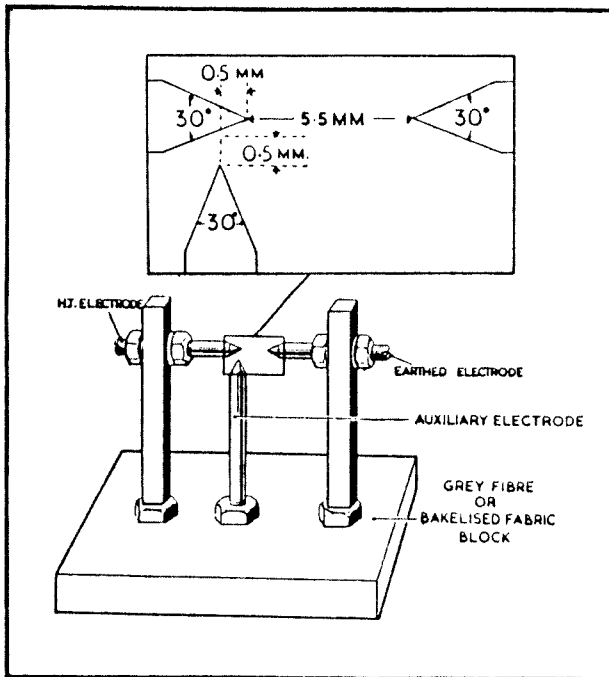

Fig. 7.
3-point spark gap

(d) TESTING THE COIL

The coil may be tested when fitted in the magneto body or removed from the magneto.

The following equipment is required:

- (i) Four-cylinder contact breaker having closed periods of not less than 42° and having an operating range up to 750 r.p.m.
- (ii) 12-volt battery.
- (iii) 3-point spark gap (see Fig. 7).
- (iv) 1-ohm resistor.
- (v) 0.5 amp. moving coil ammeter.

Testing the coil when fitted in the magneto body

- (i) Connect the lead from the coil, (normally connected to the terminal post,) to the positive terminal of the battery.
- (ii) Connect the positive terminal of the ammeter to the magneto body.
- (iii) Connect the coil, ammeter, test contact breaker and resistor across four cells (8 volts) of the battery.
- (iv) Connect a high tension cable from the contact stud on the coil to the 3-point spark gap.
- (v) Connect a cable from the 3-point spark gap to the magneto body.
- (vi) Run the contact breaker at 750 r.p.m.

Regular sparking should occur at the spark gap and the ammeter should read 0.7 to 0.8 amp.

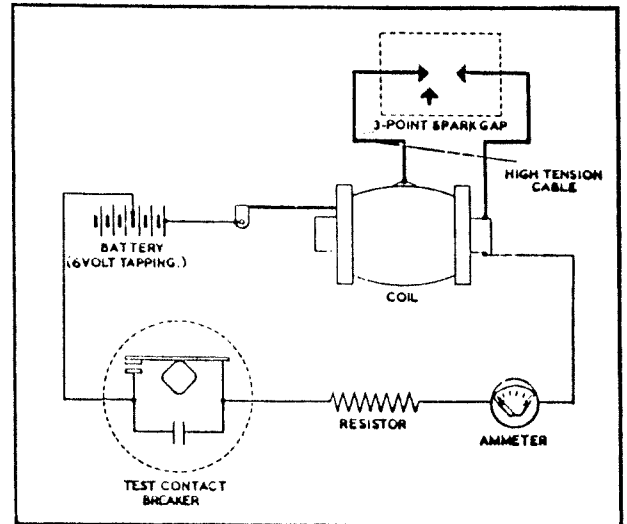

Fig. 8.
Circuit for testing magneto coil

Testing coil when removed from the magneto

- (i) Connect up as described before but remove the connections from the magneto body to the iron core of the coil, see Fig. 8.
- (ii) Reduce the battery voltage to 6 volts (three cells).
- (iii) Run the contact breaker at 750 r.p.m.

Regular sparking should occur at the spark gap and the ammeter should read 1.0 to 1.1 amp.

(e) REASSEMBLING

Before reassembling, the felt pad cam-lubricator fitted to earlier magnetos must be renewed, or the sintered iron cam fitted to later magnetos must be re-impregnated. The sintered iron cam must be immersed in medium viscosity engine oil for 24 hours.

- (i) Pack the bearings with high-melting-point grease.
- (ii) Remove all swarf and metallic objects from the rotor and insert the rotor into the magneto body.
- (iii) Refit the cut-out terminal switch and, if incorporated, the replacement terminal post.
- (iv) Insert the coil into the magneto body, so that the high tension stud faces outwards, and tighten the securing screws.
- (v) Refill the screw holes with sealing compound.
- (vi) Ensure that the shims are clean and in good condition.
- (vii) Fit the shims and contact breaker baseplate to the magneto body and tighten the securing screws.



LUCAS WORKSHOP INSTRUCTIONS

(viii) Check that the rotor turns without binding and has no end play. If necessary adjust the number of shims to give satisfactory movement. The magnetic system will oppose rotation with two points of maximum resistance in each revolution. Do not mistake this for mechanical binding.

(ix) Caulk the contact breaker base plate securing screws in position.

(x) Refit the fixed contact plate.

(xi) Place the larger, then the smaller, insulating washer on the contact breaker pivot post.

(xii) Lightly smear the pivot post with Mobilgrease No. 2.

(xiii) Fit the contact breaker lever to the pivot post.

(xiv) Refit the low tension terminal assembly in the correct order, see Figs. 1, 2 and 3.

(xv) Turn the rotor until the contacts are fully open and insert a 0.010"—0.012" or a 0.15 mm.—0.3 mm. feeler gauge in the gap. Slacken the two screws securing the fixed contact plate and move the plate until the gap is set to the thickness of the gauge. Tighten the two screws.

(xvi) If the position of the cam has been disturbed, the magneto must be retimed as follows:

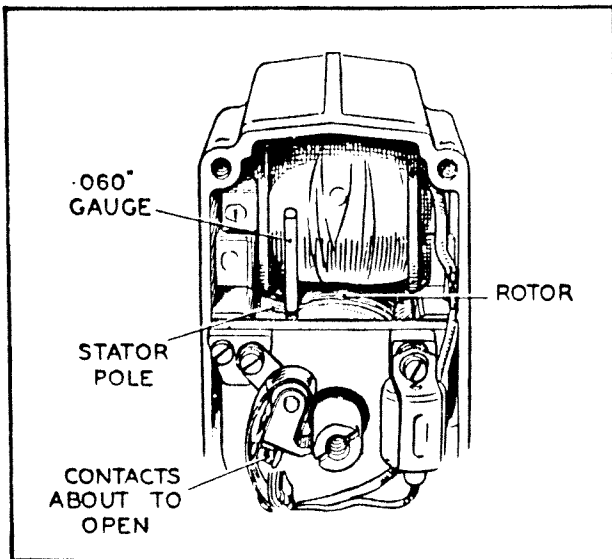

Fig. 9.
Timing model SRI

Cam Timing

'Clockwise' or 'Anti-clockwise' rotation refers to the rotation of the magneto when viewed from the driving end.

- (i) Place the cam on its taper but do not push it fully home.
- (ii) Set the contact breaker gap to 0.010"—0.012" at its maximum opening.
- (iii) Position the magneto shaft so that the driving end keyway is uppermost.

(iv) Rotate the magneto shaft in the normal direction of rotation until the keyway is off-set by an angle of about 15° from the vertical centre line of the magneto.

(v) Insert a gauge vertically between the trailing tip of the rotor pole shoe and the adjacent stator pole, see Fig. 9. The gauge must be 0.060" for single-cylinder clockwise rotation magnetos and 0.076" for single-cylinder anti-clockwise rotation magnetos and all multi-cylinder magnetos.

A drill shank forms a convenient gauge. A No. 53 drill can be used as a 0.060" gauge and a No. 48 drill as a 0.076" gauge.

(vi) Rotate the magneto shaft against normal rotation until the gauge is gripped between rotor and stator.

(vii) Adjust the position of the cam so that the contact breaker is at the point of opening and further movement of the cam in the normal direction of rotation will separate the contacts.

(viii) Tap the cam fully home.

(ix) When included, refit the rotating electrode carrier or the drive gear.

(x) Secure the cam in position by refitting the securing screw.

(xi) When included, engage the distributor gear with the drive gear so that the electrode tip on the distributor gear is in line with the bottom right-hand or top left-hand fixed electrode in the cable cover, when viewed from the drive end. Tighten the distributor gear retaining screw.

(xii) Withdraw the gauge and refit the cable cover.

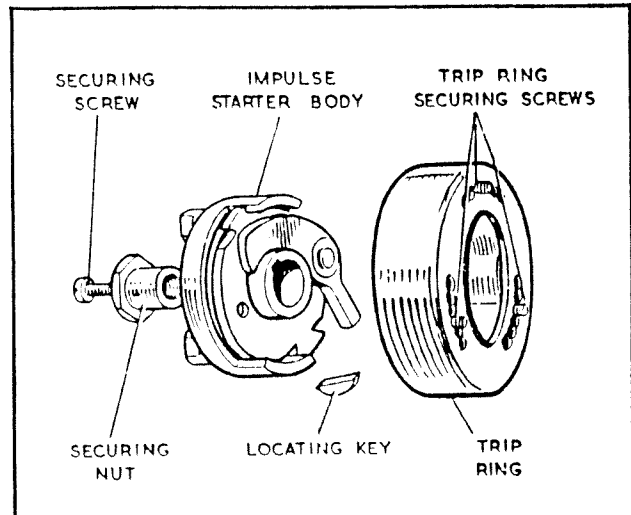

Fig. 10.
Fixed dog impulse starter

(f) SETTING AND FITTING AN IMPULSE STARTER

- (i) Lightly lubricate the impulse spring with thin machine oil.
- (ii) Reassemble the impulse spring, action plate and impulse starter body.



LUCAS WORKSHOP INSTRUCTIONS

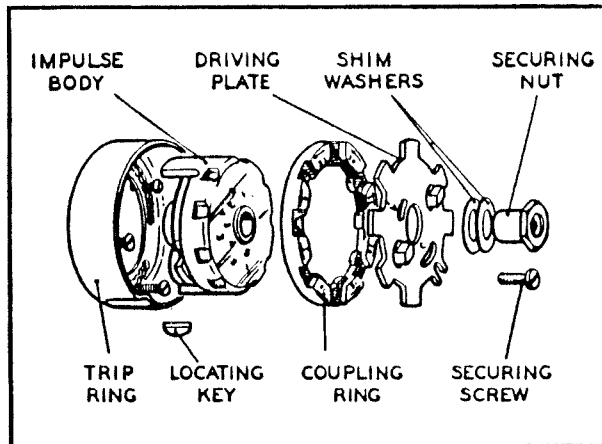

Fig. 11.
Adjustable dog impulse starter

The lag angle

As explained on page 1, an impulse starter causes a retarded spark to be produced when starting.

Due to the winding up of the impulse spring, the position of the driving dogs when a retarded spark is produced is different from their position when a normal running spark is produced.

The angular distance between these positions is called the lag angle.

This angle is determined by the engine manufacturer. In later magnetos the lag angle is adjustable.

Setting the lag angle

Angles from 0° to 35° in 5° steps can be obtained as follows:

The letters 'C' or 'A' on the trip ring refer to clockwise or anti-clockwise rotation magnetos respectively.

(i) Refer to the engine manufacturer's instructions and obtain the specified lag angle.

(ii) Fit the impulse starter trip ring to the magneto so that the marker line adjacent to 'C' or 'A' on the trip ring coincides with the required lag angle on the calibrated portion of the magneto drive end face.

As an example, to obtain a 25° lag angle with anti-clockwise rotation, place the line adjacent to 'A' against 25° on the anti-clockwise portion of the magneto calibration.

This lag angle is illustrated in Fig. 12.

The dog angle

The dog angle is the angular distance between the horizontal axis of the magneto and the position of the dogs when a normal running spark is produced. The dog angle is measured in the direction of magneto rotation. The value of the dog angle is determined by the engine manufacturer and is adjustable on adjustable dog impulse starters only.

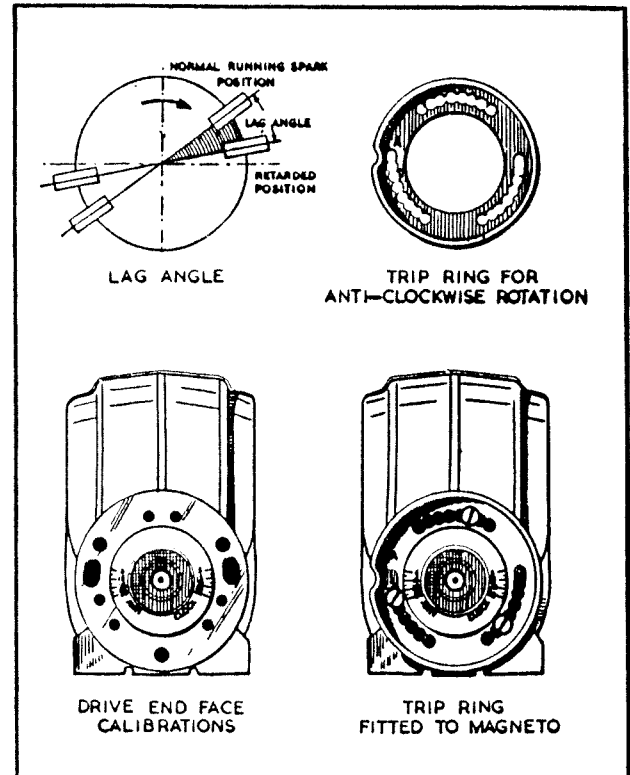

Fig. 12.
Method of setting a 25° lag angle

Setting the dog angle (Adjustable dog impulse starters only)

Dog Angle Setting Table

Dog Angles					Coupling Ring Setting
0	40	80	120	160	0
5	45	85	125	165	5
10	50	90	130	170	10
15	55	95	135	175	15
20	60	100	140	180	20
25	65	105	145	—	25
30	70	110	150	—	30
35	75	115	155	—	35
Driving Plate Window Setting					
1	2	3	4	5	

This table provides for setting dog angles from 0° to 180° in 5° steps.

(i) Refer to the engine manufacturer's instructions and obtain the specified dog angle.

(ii) Obtain the coupling ring setting number from the table. This number appears under "Coupling Ring Setting" and is in line with the relevant dog angle.



LUCAS WORKSHOP INSTRUCTIONS

(iii) Fit the driving plate to the coupling ring, so that the setting number on the coupling ring is adjacent to 'C' or 'A' on the driving plate.

(iv) Obtain the driving plate window setting number from the table. This number appears at the foot of the column in which the dog angle appears.

(v) Fit the driving plate and coupling ring assembly to the impulse body so that the required setting number on the impulse body appears in the 'C' or 'A' driving plate window.

As an example, to obtain a 175° dog angle on a magneto having anti-clockwise rotation:

Fit the driving plate to the coupling ring so that number 15 on the coupling ring is adjacent to 'A' on the driving plate

Fit the driving plate and coupling ring assembly to the impulse body so that number 5 on the impulse body appears in the 'A' driving plate window.

This dog angle is illustrated in Fig. 13.

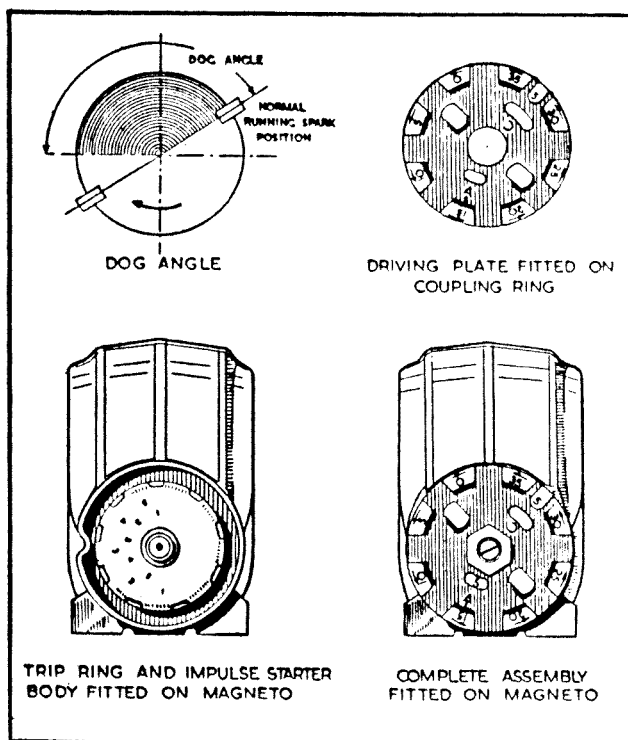

Fig. 13.
Method of setting a 175° dog angle

Fitting the impulse starter to the magneto

(i) Ensure that the trip ring is firmly secured to the magneto body.

(ii) Place the locating key in the keyway in the magneto shaft.

(iii) Press the impulse starter on the magneto shaft and engage the locating key.

(iv) Refit the securing nut. Most adjustable dog impulse starters incorporate shim washers. These must be refitted before the securing nut.

(v) Refit the left-hand threaded securing screw.

(g) FITTING AN AUTOMATIC TIMING CONTROL

(i) Lightly lubricate the governor weights, toggles and springs with thin machine oil.

(ii) Fit the timing control on the magneto shaft and tighten the securing nut.

(h) MOUNTING THE MAGNETO TO THE ENGINE

(i) Refer to the engine manufacturer's timing instructions and crank the engine until the piston in No. 1 cylinder is at the specified position with respect to T.D.C.

(ii) Remove the cable cover and turn the magneto shaft against the normal direction of rotation until the contact breaker gap just closes. With multi-cylinder magnetos the rotating electrode must be adjacent to the fixed electrode connected to the sparking plug in No. 1 cylinder.

(iii) Turn the magneto shaft in the normal direction of rotation until the contact breaker just opens. Ensure that this position is retained.

(iv) Refer to the engine manufacturer's instructions and engage the magneto with the engine drive.

(v) Secure the magneto in position by tightening the fixing screws.

(vi) Crank the engine slowly and check that the contact breaker operates correctly and that the magneto gives sparking on the power stroke.

(vii) Refit the cable cover.

